

Industry Pack Modules

IP560 CAN Bus Interface Modules

24 HOUR STOCK ITEM
2 YEAR WARRANTY

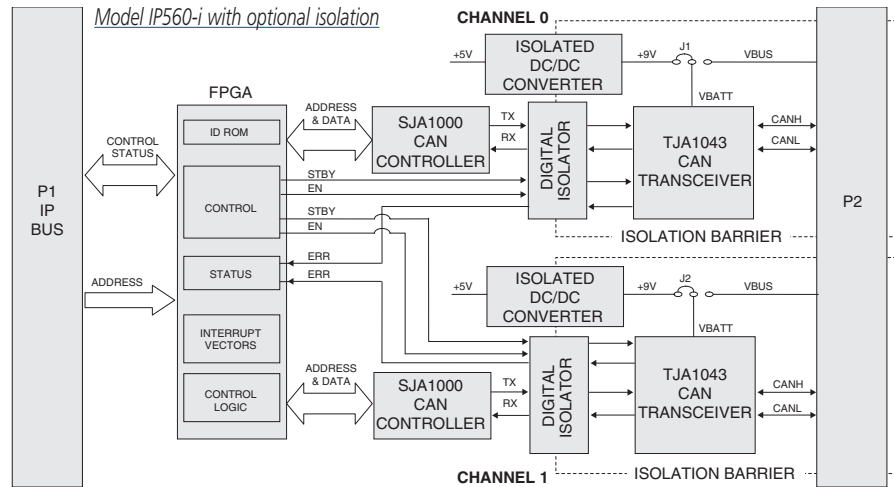
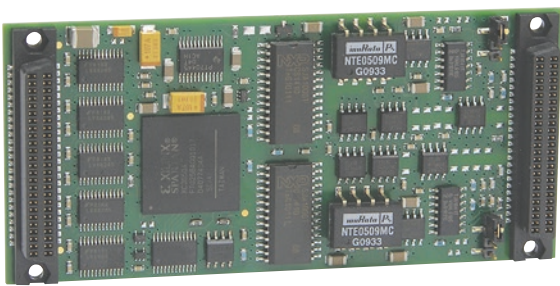

Two CAN bus channels with optional isolation ♦ NXP SJA1000 CAN controller with TJA1043 transceiver

Description

IP560 modules provide two independent CAN bus interface channels. Each channel has a NXP SJA1000 CAN controller with a TJA1043 transceiver. The advantage of this design is that it allows reporting of bus fault conditions directly from the TJA1043 transceivers. It also has the ability to transmit, receive and perform message filtering on extended and standard messages.

Using CAN to network controllers, actuators, sensors, and transducers provides many benefits to system developers. First, the ready availability of multi-sourced components and tools can significantly reduce design time. Next, the small, light cables used by CAN help lower connection costs. Additionally, CAN has fewer connections which improves reliability.

CAN is ideal for the following applications:

- Marine control and navigation systems
- Elevator control systems
- Defense vehicles
- Production line control systems
- Machine tools
- Large optical telescopes
- Medical systems
- Paper and textile production machinery
- Packaging machinery

Key Features & Benefits

- Two complete CAN bus interfaces
- NXP SJA1000 CAN bus controller with high-speed TJA1043 CAN transceiver
- 1000V isolation, channel-to-channel and channel-to-host (IP560-i models)
- ISO 11898 compliance for Part A (11-bit) and Part B extended (29-bit) arbitration IDs
- CAN 2.0B protocol compatibility (extended frame passive in PCA82C200 compatibility mode)
- Data rates of up to 1Mb/s
- Supports both 8MHz and 32MHz IP operation
- 0 to 70°C or -40 to 85°C operating temperature range
- TXD dominant clamping handler with diagnosis
- RXD recessive clamping handler with diagnosis
- TXD-to-RXD short-circuit handler with diagnosis
- Bus line short-circuit diagnosis
- Bus dominant clamping diagnosis
- PCA82C200 mode (BasicCAN mode is default)
- Extended receive buffer (64-byte FIFO)
- 24 MHz clock frequency
- PeliCAN mode extensions:
 - Error counters with read/write access
 - Programmable error warning limit
 - Last error code register
 - Error interrupt for each CAN-bus error
 - Arbitration lost interrupt with detailed bit position
 - Single-shot transmission (no re-transmission)
 - Listen only mode (no acknowledge, no active error flags)
 - Hot plugging support (software driven bit rate detection)
 - Acceptance filter extension (4-byte code, 4-byte mask)
 - Reception of 'own' messages (self reception request)
- Undervoltage detection on VBAT
- Listen-only mode for node diagnosis and failure containment

Acromag 
THE LEADER IN INDUSTRIAL I/O

Tel 248-295-0310 ■ Fax 248-624-9234 ■ solutions@acromag.com ■ www.acromag.com ■ 30765 Wixom Rd, Wixom, MI 48393 USA

Industry Pack Modules

IP560 CAN Bus Interface Modules

Performance Specifications

■ CAN Bus

Configuration

Two independent CAN bus channels.
NXP SJA1000 CAN controller with TJA1041 transceiver.

ISO 11898 standard

Supports the standard data and remote frame as well as the extended data and remote frame according to CAN specification 2.0 Part A and Part B.

Isolation

IP560: Non-isolated. Logic and field commons have a direct electrical connection.

IP560-i: 1kV DC isolation.

Maximum data rate

1Mb/S.

■ IP Compliance (ANSI/VITA 4)r

Meets IP specifications per ANSI/VITA 4-1995 (R2002).

Data transfer cycle types supported:

Input/output (IOSel*), ID read (IDSel*), Interrupt Select (INTSel*), Memory (MEMSel*).

Access times (8MHz clock)

ID PROM Read: 1 wait state (375nS cycle).

I/O Space Read: 1 wait state (375nS cycle).

I/O Space Write: 0 wait state (250nS cycle).

Interrupt Select Read: 1 wait state (375nS cycle).

Memory Space Read: 3 wait state (750nS cycle).

Memory Space Write: 2 wait state (625nS cycle).

Access times (32MHz clock)

ID PROM Read: 1 wait state (94nS cycle).

I/O Space Read: 1 wait state (94nS cycle).

I/O Space Write: 0 wait state (63nS cycle).

Interrupt Select Read: 1 wait state (94nS cycle).

Memory Space Read: 5 wait state (250nS cycle).

Memory Space Write: 2 wait state (156nS cycle).

■ Environmental

Operating temperature

0 to 70°C or -40 to 85°C (E models).

Storage temperature

-55 to 125°C.

Relative humidity

5 to 95% non-condensing.

Power

IP560/IP560E

+5V (±5%): 92 mA typical, 110 mA maximum.

+12 Volts (±5%): 0.12 mA typical, 0.2 mA maximum.

IP560-i/IP560E-i

+5V (±5%): 123 mA typical, 275 mA maximum.

MTBF

Contact the factory.

Ordering Information

IP Modules

IP560

Dual-channel CAN bus interface module.

IP560E

Same as IOS-560 plus extended temperature range.

IP560-i

Dual-channel isolated CAN bus interface module.

IP560E-i

Same as IOS-560-i plus extended temperature range.

Carrier Cards

See www.acromag.com for more information.

Software development tools

See www.acromag.com for more information.

ISO9001
AS9100 
MADE IN USA

Acromag 
THE LEADER IN INDUSTRIAL I/O

Tel 248-295-0310 ■ Fax 248-624-9234 ■ solutions@acromag.com ■ www.acromag.com ■ 30765 Wixom Rd, Wixom, MI 48393 USA