

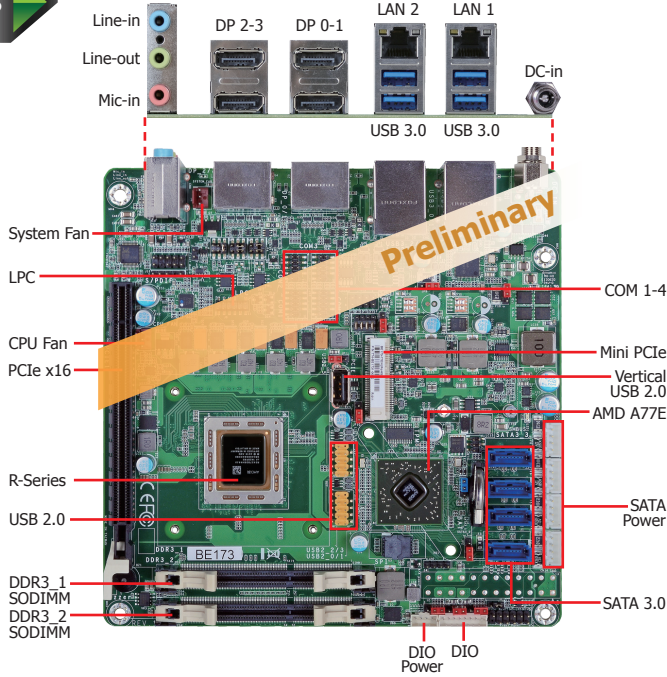

2nd Gen AMD® Embedded R-Series Mini-ITX

BE171/BE173

R-Series



* The photos above refer to BE173.

| Model Name | Power |
|------------|--------------|
| BE171 | 12V DC-in |
| BE173 | 19~24V DC-in |

Features

| | |
|-----------------|-----------------------------|
| MEMORY | 2 DDR3 SODIMM up to 16GB |
| EXPANSION | 1 PCIe x16 1 Mini PCIe |
| DISPLAY OUTPUTS | 4 DP |
| LAN | 2 LAN |
| COM | 4 COM |
| USB | 9 USB: 4 USB 3.0, 5 USB 2.0 |
| STORAGE | 4 SATA 3.0 |
| DIO | 8-bit DIO |



Mechanical Drawing



Block Diagram

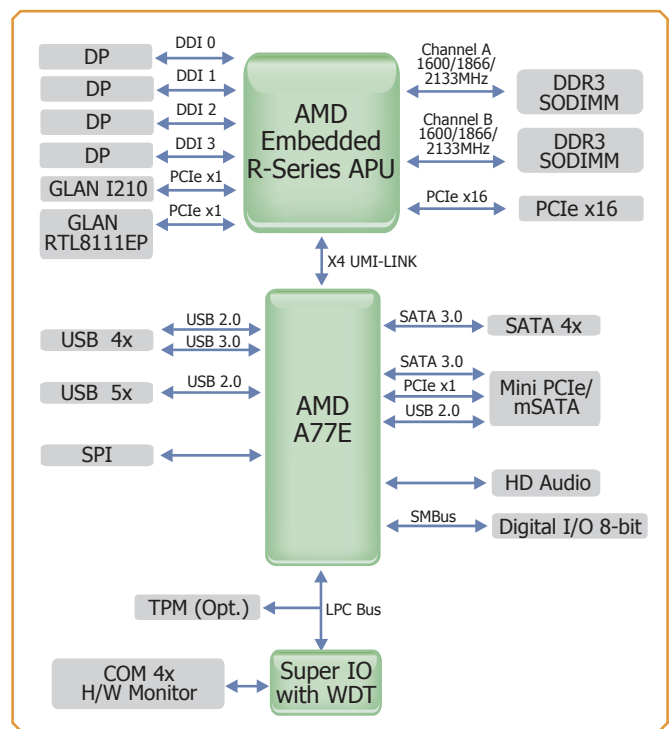

BE171/BE173

► **Specifications** * Optional and is not supported in standard model. Please contact your sales representative for more information.

APU (Accelerated Processing Unit)

- 2nd Generation AMD® Embedded R-Series APU FP3 BGA
- 28nm process technology
- Please refer to the Ordering Information below*

CHIPSET

- AMD® A77E Fusion Controller Hub

SYSTEM MEMORY

- Two 204-pin SODIMM sockets
- Supports DDR3 1600/1866/2133MHz
- Supports up to 16GB system memory
- Supports dual channel memory interface
- DRAM device technologies: 1Gb, 2Gb and 4Gb DDR3 DRAM technologies are supported for x8 and x16 devices, unbuffered, non-ECC

EXPANSION SLOTS

- 1 PCIe x16 Gen 3 slot (PCIe 3.0)
- 1 Mini PCIe slot
 - Supports USB and PCIe signals
 - Supports mSATA
 - Supports half size and/or full size Mini PCIe card

ONBOARD GRAPHICS FEATURES

- AMD Radeon™ HD 9000 Series Graphics
- Display ports: 4 DP (supports DP++)
- DP: resolution up to 3840x2160 @ 30Hz
- HDMI: resolution up to 4096x2160 @ 24 Hz
- Supports hardware acceleration for DirectX 11.1, OCL 1.2, OGL 4.1/4.1+, H.264, VC-1, MPEG-4, MPEG-2 and WMV

ONBOARD AUDIO FEATURES

- Realtek ALC888 7.1-channel High Definition Audio
- S/PDIF audio interface

ONBOARD LAN FEATURES

- 1 Intel® I210 PCI Express Gigabit Ethernet controller
- 1 Realtek RTL8111EP Ethernet controller
 - supports DASH for remote management
- Integrated 10/100/1000 transceiver
- Fully compliant with IEEE 802.3, IEEE 802.3u, IEEE 802.3ab

SERIAL ATA INTERFACE

- 4 SATA 3.0 ports with data transfer rate up to 6Gb/s
 - SATA port 0 provides adequate space for SATA DOM
- Integrated Advanced Host Controller Interface (AHCI) controller

TRUSTED PLATFORM MODULE (TPM)*

- Provides a Trusted PC for secure transactions
- Provides software license protection, enforcement and password protection

WATCHDOG TIMER

- Watchdog timeout programmable via software from 1 to 255 seconds

REAR PANEL I/O PORTS

- 1 12V (BE171) or 19~24V (BE173) DC-in jack or 4-pin power connector*
- 4 DP ports
- 2 RJ45 LAN ports
- 4 USB 3.0 ports
- Mic-in, line-in and line-out jacks

I/O CONNECTORS

- 2 connectors for 4 external USB 2.0/1.1 ports
- 1 vertical USB 2.0/1.1 port
- 4 connectors for 4 external serial ports (2.0mm pitch)
 - 1 RS232/422/485
 - 3 RS232
- 1 8-bit DIO connector
- 1 Digital I/O power connector
- 1 front audio connector for line-out and mic-in jacks
- 1 S/PDIF connector
- 1 LAN LED connector*
- 1 LPC connector
- 1 SMBus connector
- 4 Serial ATA connectors
- 4 Serial ATA power connectors
- 1 front panel connector
- 1 chassis intrusion connector
- 2 fan connectors

BIOS

- AMI BIOS
- 64Mbit SPI BIOS

ENERGY EFFICIENT DESIGN

- Supports ErP Lot6 power saving*
- Supports ACPI
- System Power Management
- Wake-On-Events include:
 - Wake-On-USB KB/Mouse
 - Wake-On-LAN
 - RTC timer to power-on the system
- AC power failure recovery

DAMAGE FREE INTELLIGENCE

- Monitors APU/system temperature and overheat alarm
- Monitors APU_VDD/APU_VDDNB/APU_VDDIO_SUS/+12V voltages and failure alarm
- Monitors APU/system fan speed and failure alarm
- Read back capability that displays temperature, voltage and fan speed

POWER CONSUMPTION

- TBD

OS SUPPORT

- TBD

TEMPERATURE

- Operating: 0°C to 60°C
- Storage: -20°C to 85°C

HUMIDITY

- 10% to 95%

DIMENSIONS

- Mini-ITX form factor
- 170mm (6.7") x 170mm (6.7")

► **Power Connector**

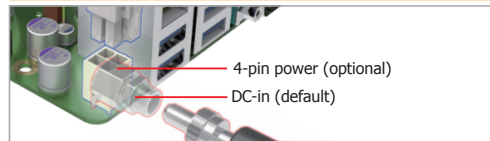

► **Ordering Information**

| Model Name | Processor | SOMIMM | RS232 | RS232/422/485 | Power | Thermal | Temperature |
|-----------------|--|----------|-------|---------------|--------------|---------|-------------|
| BE171-77EN-427B | AMD® RX-427BB, Quad Core, 4M Cache, 2.7GHz (3.6GHz), 35W | 2 (16GB) | 3 | 1 | 12V DC-in | Fanless | 0°C to 60°C |
| BE171-77EN-225B | AMD® RX-225FB, Dual Core, 1M Cache, 2.2GHz (3.0GHz), 17W | 2 (16GB) | 3 | 1 | 12V DC-in | Fanless | 0°C to 60°C |
| BE173-77EN-427B | AMD® RX-427BB, Quad Core, 4M Cache, 2.7GHz (3.6GHz), 35W | 2 (16GB) | 3 | 1 | 19~24V DC-in | Fanless | 0°C to 60°C |

The following specifications will be available upon request. Please contact your sales representative for more information.

| | Power | Chipset | Processors |
|------|---------------------------------|---------|--|
| BE17 | 1 | - 77E | N - 425B |
| | 1: 12V DC-in 3: 19~24V DC-in | | 425B: AMD® RX-425BB, Quad Core, 4M Cache, 2.5GHz (3.4GHz), 35W |

► **Packing List**

- 1 BE171/BE173 motherboard
- 1 Serial ATA data with power cable: A81-002013-000G
- 1 I/O shield: A49-BE1700-000G
- 1 QR (Quick Reference)
- 1 DVD
- 1 Heat sink: A71-108004-00000G

► **Optional Items**

- USB port cable: 332-253010-026G
- COM port cable: A81-015001-000G
- Serial ATA data with power cable: A81-002013-000G
- I/O shield: A49-BE1700-000G
- Power adapter (100W, 12V) : 671-110001-100G
- Power adapter (120W, 19V) : 671-112004-100G